



NOVATOP ACOUSTIC
Instructions for installation

INSTRUCTIONS FOR INSTALLATION CONTENT

CONTENT

INSTRUCTIONS FOR INSTALLATION

1	Tools for assembly	4
2	General information	4
3	Safety at work	4
4	Types of applications	4
5	Installation recommendations	5
6	Types of applications	5
7	Assembly	5
8	Anchoring of horizontal and vertical structures	6-7
9	Manual machining of panels	8
10	Details of the corners	8-9
11	Continuity of ceiling and wall panels	10
12	Termination	10
13	Recommended applications	10



 **YouTube**
Video tutorial

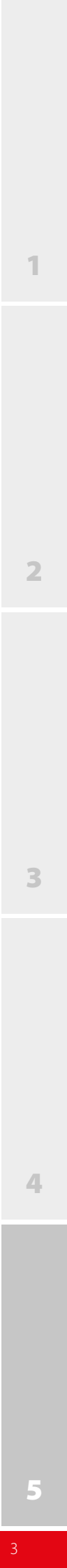

CONTENT

The assembly instructions contain basic information and recommendations. Responsibility for the correct execution is assumed by the implementing company that complies with the current technical standards.

1 TOOLS FOR ASSEMBLY

- Screws with a narrow head
- Cordless screwdriver
- Spirit level
- Ladders, lifting platforms, mobile scaffolding
- The recommended number of persons, minimum 2

2 GENERAL INFORMATION

It is recommended to:

- Wear gloves during work due to possible contamination of the panels or getting a splinter.
- Perform installation of the panels after all „wet“ and „dirty“ processes have been finished.
- Wipe the dirty areas locally with a damp cloth or abrade them with sandpaper.
- Machine the panels with all standard woodworking tools and machines and to treat their surface by conventional procedures as solid wood.
- Relative humidity of indoor environment during assembly of up to 55 % at 20 °C.

It is not recommended to:

- Step on the visual surfaces of the panels or otherwise stain them.
- To expose the panels to direct sunlight, which prevents possible discolouration.

Storage:

- The panels must be stored in a dry place and must be protected against weather conditions.
- The panels must be stored on hard and flat surfaces with the possibility of secure access and manipulation.
- Disposal of packaging materials must be carried out in accordance with the local regulations and directives on waste management.



3 SAFETY AT WORK

When handling the panels, it is necessary to:

- Observe all safety precautions.
- Use appropriate personal protective equipment.
- Extreme care must be exercised when working at heights and on lifting platforms.
- Secure the panels against falling.

4 TYPES OF APPLICATIONS

Horizontal and vertical structures

- In the case of using both horizontal and vertical structures, we expect some movement between the panel and the base.
- When using panels over large areas, emphasis must be placed on proper foundation and mutual fastening of individual panels.
- It is necessary to think about the position of wiring and prepare all entries and openings.
- Panel connections should be overlapping: see pictures. Connections that are not overlapping demand greater accuracy and execution.

Not recommended

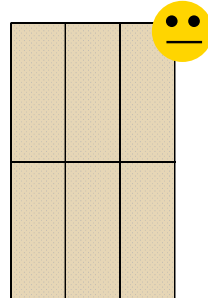

Recommended

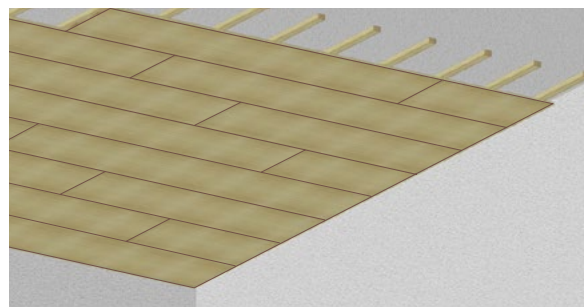
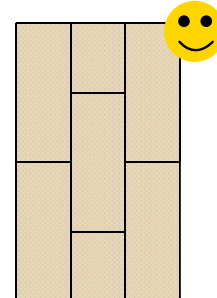

A horizontal structure (ceiling) - set-over connections

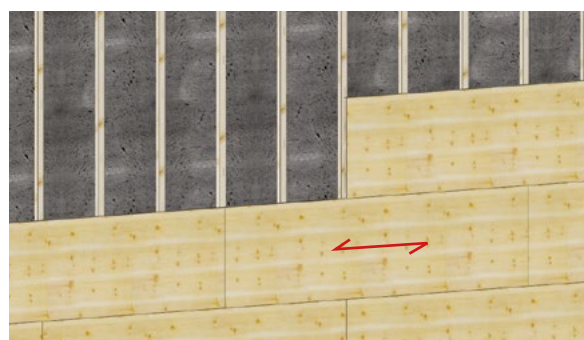

Vertical structure (wall) - horizontal placement

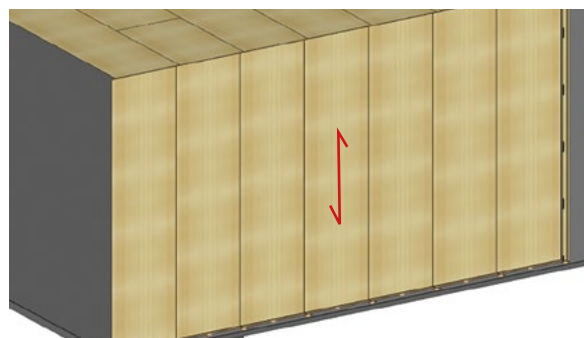

Vertical structure (wall) - vertical placement

NOVATOP ACOUSTIC ASSEMBLY

CONTENT

5 RECOMMENDATIONS FOR ASSEMBLY

Preparation of the base grid

- When preparing the grid, it is necessary to take into account unevenness of the base and to decrease the span of the first batten, so that it was possible to adjust the width of the first acoustic panel.
- On the base designed for the lining, we will prepare a balancing grid in a screen which we will measure depending on the size of the acoustic panels and the area designed for the lining. The gap between the base and the acoustic panel can also accommodate wiring or other distributions.
- After installing the base grid, do not forget to mark the ribs on visible places, so that they are visible even after being covered with acoustic panels.

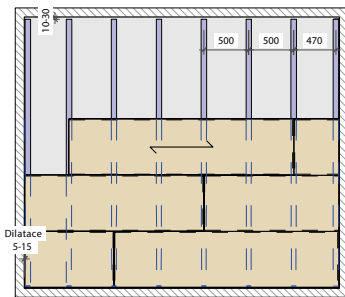

Screen of a balancing grid - transverse (for Giulia -1,000 mm)
If necessary, 250 mm can be used.

6 TYPES OF APPLICATIONS

6.1 No grid (e.g. with NOVATOP, OSB, SDK)

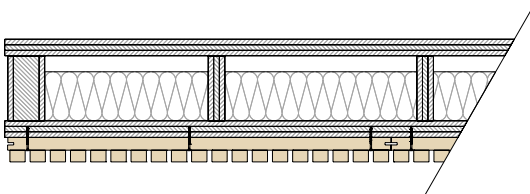

6.2 Wooden grid (bottom view)

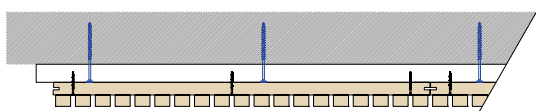

Contact wooden grid

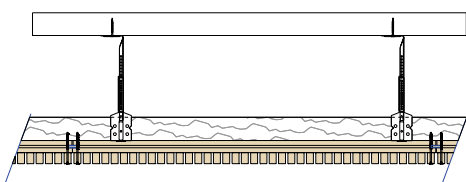

Suspended wooden grid

6.3 Metal-sheet grid

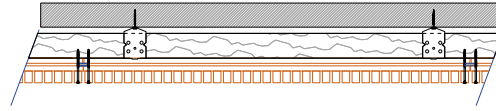

Contact metal-sheet grid

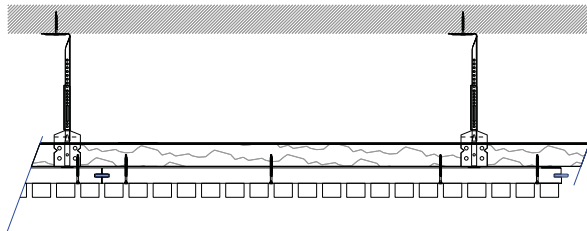

Suspended metal-sheet grid

7 ASSEMBLY

- When laying the panels, it is necessary to keep the flatness, preferably using a stretched string, in order to avoid gaps between the panels during further laying of panels.
- When assembling, it is necessary to follow the continuity of the grooves from one panel to the other.
- For the mutual connection of the panels, either inserted springs or special connecting elements of plywood in prepared local grooves that are supplied.
- It is necessary to take into account the position of the accouplements to eliminate loose ends.
- We recommend calculating the size of the trimming that will be made at the end of the area that is lined, so that only a small band is left.
- We recommend using residues only over 500 mm.

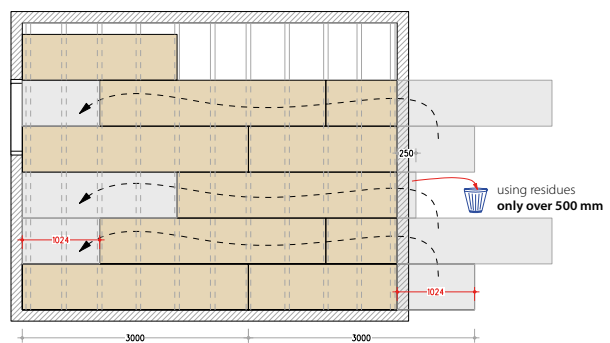

Laying diagram and work with panel trimmings

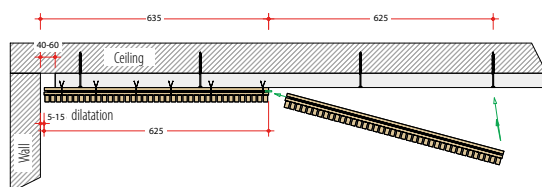

Linking of panels

CONTENT

8 ANCHORING

- Acoustic panels can be anchored on both horizontal and vertical structures using: anchoring screws, clips into grooves or by gluing according to the type of the structure. We have to make sure that the connecting elements are in one line and, if possible, without damaging the surface of the acoustic panel.
- **Warning:** loads (lights, fluorescent lamps etc.) cannot be suspended from a ceiling made of acoustic panels, all loads must be positioned on the bearing structure!

8.1 HORIZONTAL STRUCTURES

Anchoring with screws

- If screws are applied into a groove, it is necessary to use screws with a smaller head size than the groove of the panel, so that the heads will not damage the groove (e.g. screws made by HPM-TEC Rothoblaas, Würth).
- **The minimum size of the screws is 3.2 x 50 mm.**
- **The minimum number of screws is 8 pcs/m².** (A general rule applies: each accouplement of the panel must be screwed in such a way so that the panel will not bend.)

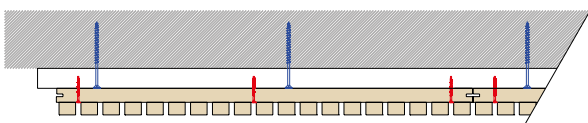

Screws in the 8 mm groove – standard screws

Special screws for anchoring

- Special screws for easy anchoring directly into the groove of the panel with a 4 mm head
- Developed directly for the needs of the most requested profiles: Acoustic Marilyne 4/12 and Marilyne S1, S2
- Easy application without damaging the surface of the acoustic panel
- Possibility of anchoring to horizontal and vertical structures
- Recommended amount: 10 pcs/m²
- Can only be delivered as part of the order, 250 pcs packaging.

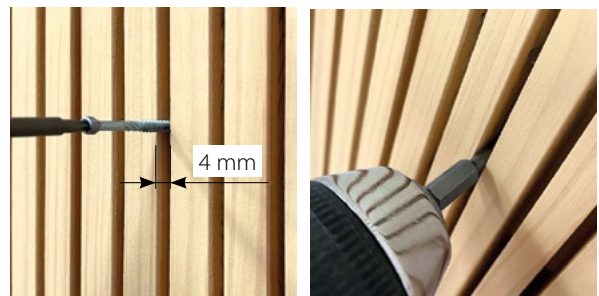
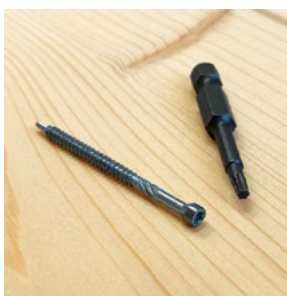

Surface anchoring

- In the area of the panel, we recommend using screws at least 4 x 70 mm made of stainless steel or hot dip galvanized.
- **The minimum number of screws is 8 pcs/m².**

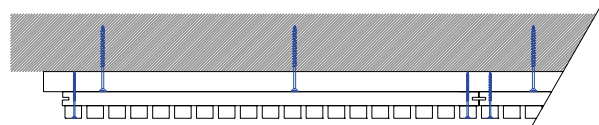

Screws in the area of the panel

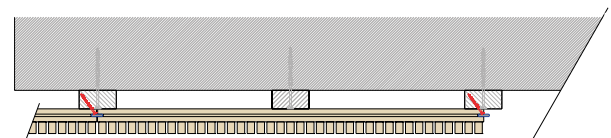

Screws into a side groove with a base grid

Anchoring with clips into grooves

- **The minimum length of the clips is 38 mm** (clips made by e.g. the company Reich 1.8/38 mm).
- We recommend using anchoring with clips e.g. with the profile Marilyne where the thickness of the groove is only 4 mm and screws into a groove cannot be used. It is advisable to use an air pistol with a narrow end (e.g. made by the company Reich).
- **The minimum number of clips is 10 pcs/m²** (approximately 2 pcs of clips 1.8/38 per 1 accouplement of the width of 80 mm while the span of the base grid is 625 mm and the span of the accouplements is 500 mm from one another).

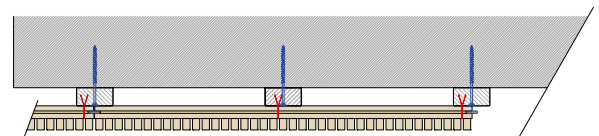

Clips into a groove with a base grid (Marilyne 4-12)

1

2

3

4

5

NOVATOP ACOUSTIC ASSEMBLY

CONTENT

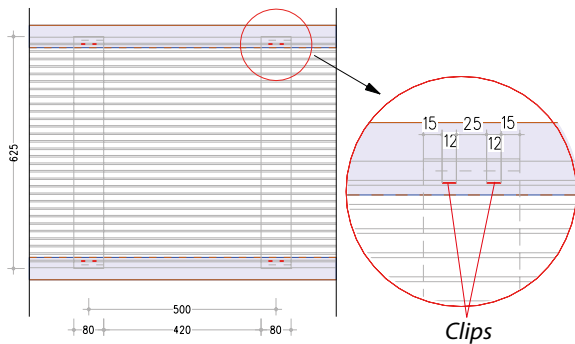

2 clips can be positioned on 1 accouplement. Their span must be at least 25 mm



An air pistol with a narrow end (Reich)

Gluing

- Glue acoustic panels using a special gluing system with a base grid (e.g. SIKA TACK). Gluing must be performed in compliance with the instructions given by the gluing system manufacturer.

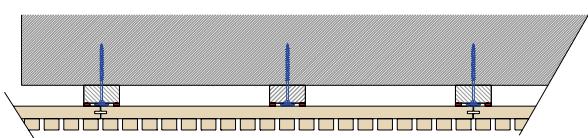

8.2 VERTICAL STRUCTURES

Anchoring with screws

- As with the horizontal structures, it is important to align the underlying battens of the vertical structures as well. It is necessary to take into account the movement of joints of both the floor and the ceiling structures.
- Anchoring vertical structures can be achieved with screws, clips and gluing.
- **The minimum number of screws is 8 pcs/m².**

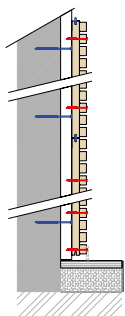

Screws in the area of the panel

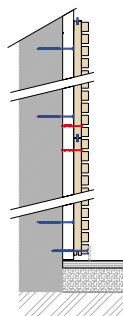

Screws in the groove

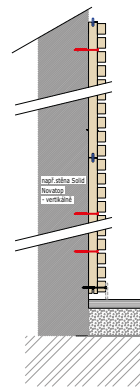

Screws in a groove on a SOLID

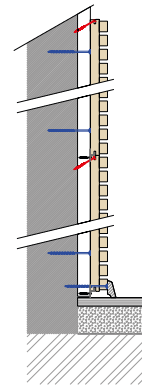

Screws into a side groove

Anchoring with clips into grooves

- The minimum number of clips is 10 pcs / m².

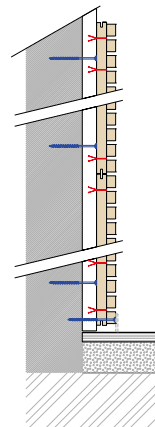

Clips into a groove with a base grid

Gluing

- Glue acoustic panels using a special gluing system with a base grid (e.g. SIKA TACK). Gluing must be performed in compliance with the instructions given by the gluing system manufacturer.

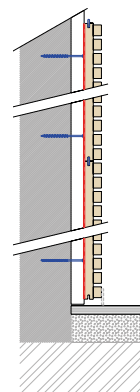

Gluing

CONTENT

9 MANUAL MACHINING OF PANELS

General information

- The panels can be machined by conventional methods and/or with standard hand tools.
- The panels can be cut, drilled, sanded, etc., the same as solid wood.
- When machining (drilling, cutting - transverse and oblique) visual quality surfaces, a protective lamella can be used in the grooves of the panel, which prevents chipping and fraying of the cut.
- When drilling a hole for wiring or another opening, make sure that the hole is in the correct position and that other structures do not block these openings (suspension grids, hangers, etc.).

Transverse and oblique cutting

- It is ideal to make the cut at the location of the accouplement, with loose ends over 150 mm, we recommend adding additional accouplements to eliminate twisting the slats of the loose ends.
 - With transverse and oblique cuts, it is advisable to use a protective lamella in the grooves of the acoustic panels.
- Recommendation:** in order to prevent fraying of the visual surfaces, we cut the panel from the back side.
- When cutting, it is necessary to use a liner or a guide bar, which guarantees a straight cut.
 - A rectilinear vibrating saw can be used with curvilinear cuts. **Warning:** There is a risk of fraying.

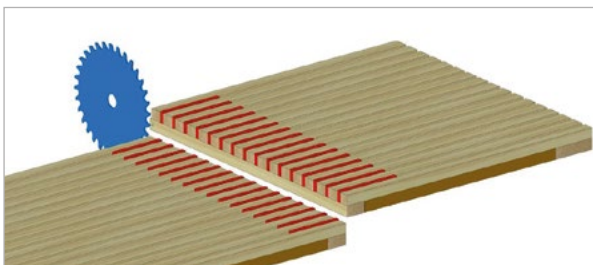

Cutting with protective lamellas

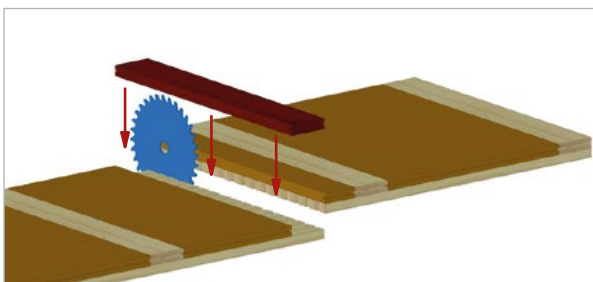

Cutting from the back side

Drill holes, jigsawing

- Drill holes and openings of various diameters using drills, jigsaws, milling cutters, etc., can be made into acoustic panels.
- When machining, it is advisable to use a protective lamella in the grooves of the acoustic panels.

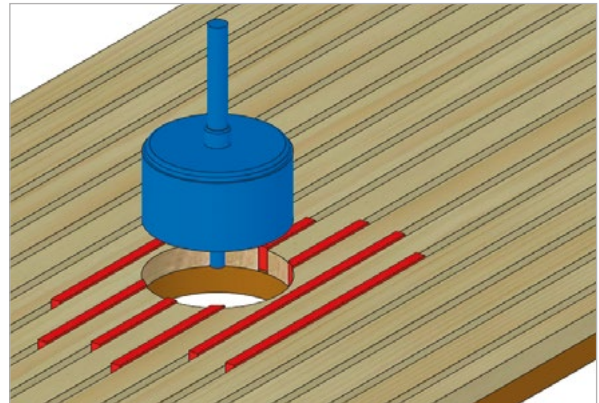

Jigsawing with protective lamellas

10 Details of various executions

Sharp outer corner

- The corners should be cut at an angle of 45°.
- The connection must be executed as accurately as possible; minimum deviations from the flatness of the base are permitted.
- When cutting at an angle, it is necessary to use a new, sharp cutting disc and cut the panel from the back so as not to fray the front visible edges of the panel.
- When cutting, we recommend using a guide bar or a ruler.
- The corners can also be prepared on a table sizing saw with scoring.
- We recommend cutting at the place of the accouplement.

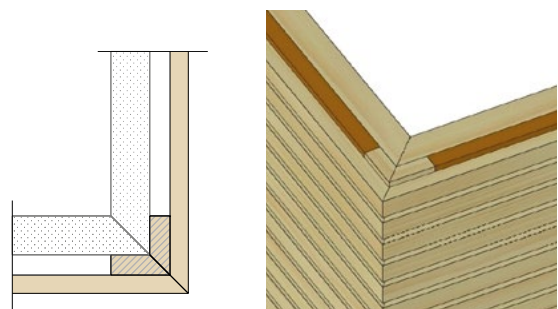

1

2

3

4

5

NOVATOP ACOUSTIC ASSEMBLY

CONTENT

Outer corner with a partly flat front

- The corners are cut at an angle of 45°.
- The angle in the corner of the panel is cut in such a way so as to form a small (about 2 mm) flat front area.
- The advantage of the connection is that it is not so sharp and minor inaccuracies are much less visible.

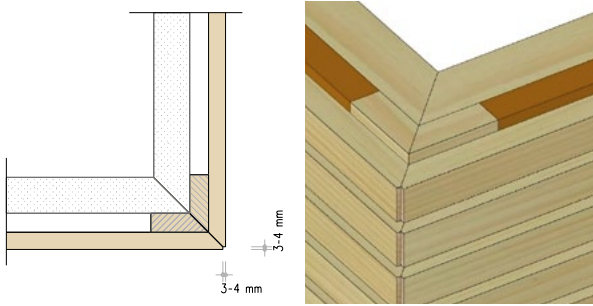

Outer corner with a partly flat front and a slat on the face side

- The corners are cut at an angle of 45°.
- There is a slat between individual panels that equalizes unevenness and creates a safe corner without sharp edges.

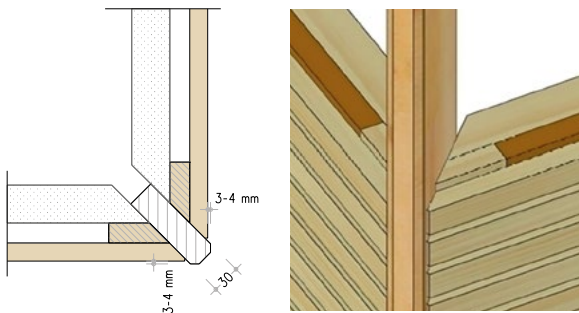

Outer corner with a slat on the face side

- The connection must be executed as accurately as possible; minimum deviations from the flatness of the base are permitted.
- With this connection, emphasis is placed on accuracy and precision of execution.

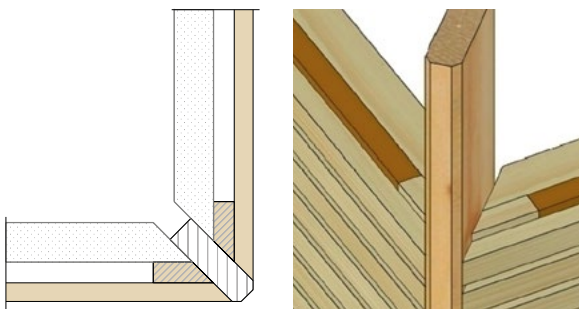

Inner corner with a visual joint

- The simplest execution of the inside connection, the optimum joint is 4-8 mm

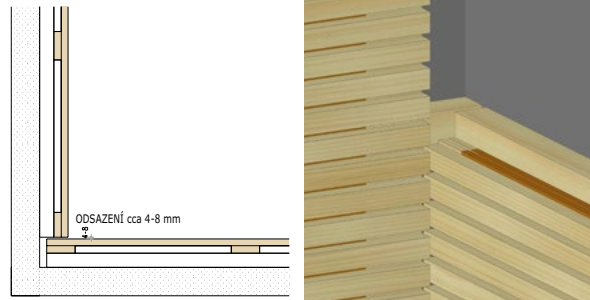

Inner corner with a partial bevel

- This connection is more demanding as for accuracy and execution and is effective.

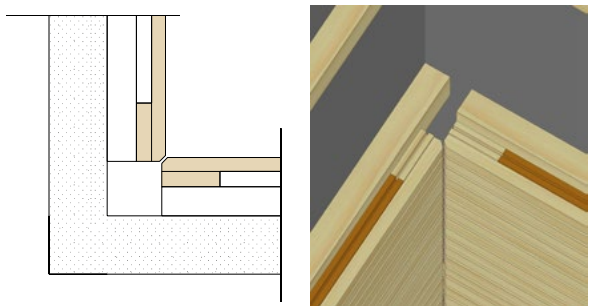

Inner corner with a corner pole

- This connection is conducted the following way: a pole with a bevelled edge is put in the corner prior to the assembly of the acoustic panels and the acoustic panels are finished close to the pole, or it is possible to leave a visual joint between the pole and the panel 3-4 mm.

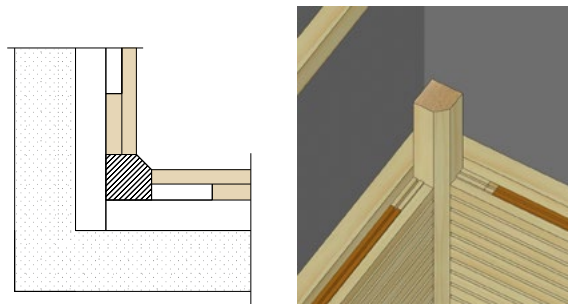

1

2

3

4

5

CONTENT

11 Continuity of ceiling and wall panels

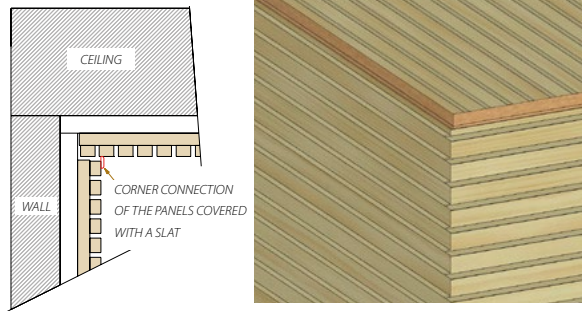

Detail of finishing with a slat

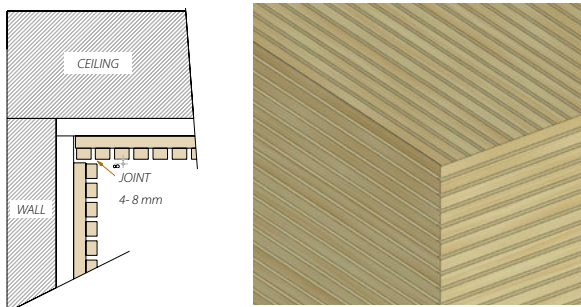

Detail of finishing with a visual joint

12 FINISHING OF ACOUSTIC PANELS

Horizontal structures

- We recommend finishing the acoustic panel with a visual joint a covering it with a slat.

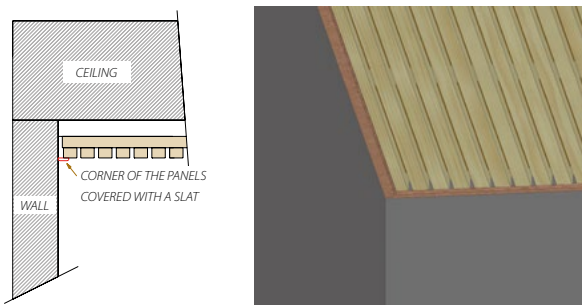

Detail of finishing with a slat

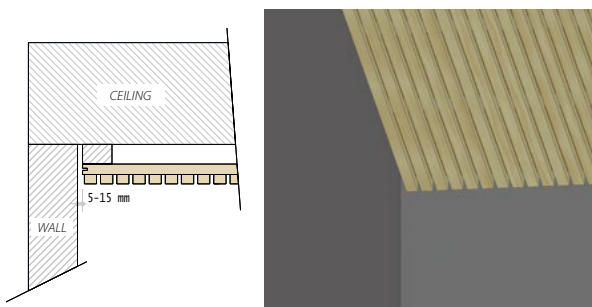

Detail of finishing with a visual joint

Vertical structures

- Due to possible unevenness of the floors, subsidence and other circumstances that affect the assembly, it is recommended finishing the acoustic panel just above the floor and create a detail with a visual joint or to cover the joint with a slat. See the pictures.



Detail of finishing with a slat

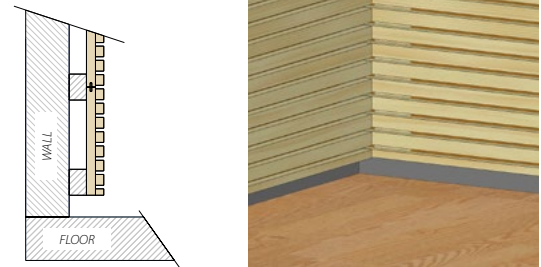

A detail of finishing the acoustic panel 50 mm above the floor

13 RECOMMENDED APPLICATION

Application on horizontal and vertical structures

- Family homes, flats
- Auditoriums and lecture halls
- Offices
- Car showrooms
- Concert halls
- Educational facilities
- Sports halls and gymnasiums
- Sacral buildings

1

2

3

4

5

NOTES

CONTENT

Grid of dots for notes.

1

2

3

4

5

CONTENT

1	
2	
3	
4	
5	

EXAMPLES OF APPLICATIONS

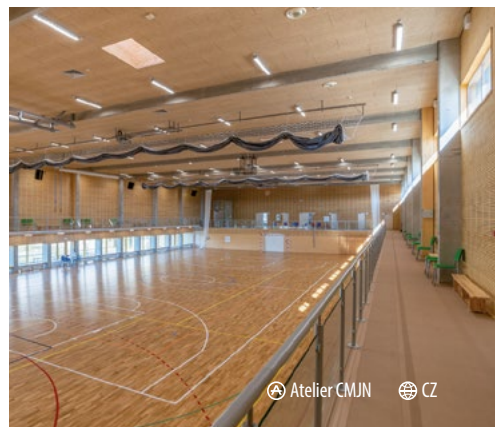

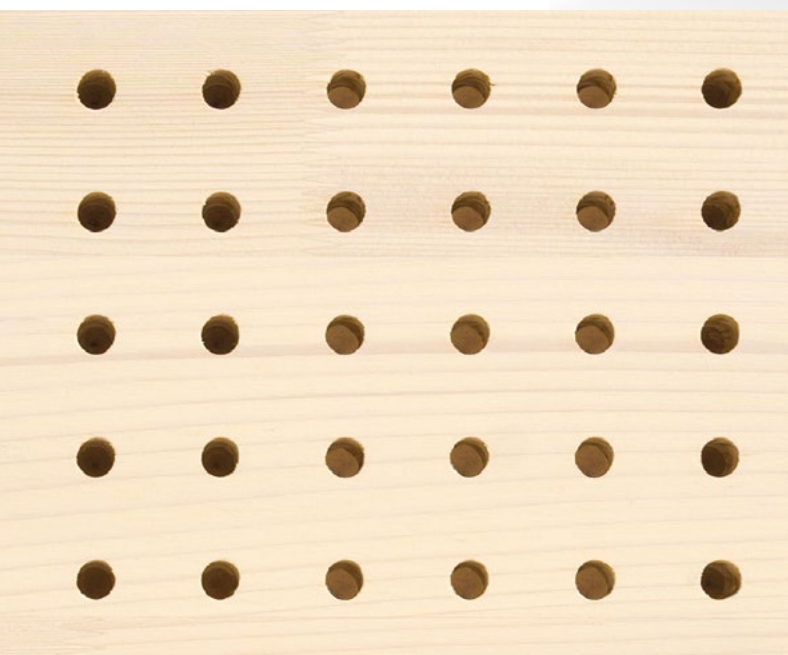

www.novatop-system.com

Manufacturer: AGROP NOVA a.s.
Ptenský Dvůrek 99 • 798 43 Ptení
Czech Republic • Tel.: +420 582 397 856
novatop@agrop.cz • www.novatop-system.com

Manufacturer certificates:

